

Machine type: 10156/90AJ [H500]

# Lenovo H5 Series User Guide

Version 1.0 2013.10

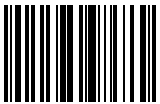

31505986



***lenovo***

# Important Safety Information

Before using this manual, it is important that you read and understand all of the related safety information for this product. Refer to the *Safety and Warranty Guide* that you received with this product for the latest safety information. Reading and understanding this safety information reduces the risk of personal injury or product damage.

The interface and functions shown in this User Guide are provided for reference only and may differ from actual product appearance. Product design and specifications may be changed without notice.



**Danger:** Be aware of extremely hazardous or potentially lethal situations.



**Attention:** Be aware of possible damage to programs, devices, or data.



**Note:** Pay attention to this important information.

© Copyright Lenovo 2013. All rights reserved.

LIMITED AND RESTRICTED RIGHTS NOTICE: If data or software is delivered pursuant a General Services Administration "GSA" contract, use, reproduction, or disclosure is subject to restrictions set forth in Contract No. GS-35F-05925.



# Contents

## Important Safety Information

### **Using the Computer Hardware ..... 1**

- Front view of the chassis .....2
- Rear view of the chassis.....3
- Basic connector instructions .....4
- Connecting your computer.....5
- 5.1 Audio configuration instructions.....6
- Connecting the power cord.....7
- Display connecting instructions when playing Blu-ray Discs.....8
- Connecting to the Internet.....8
- Wired keyboard (selected models only) .....9

### **Using Windows 8..... 11**

- Switching between the main Windows 8 interfaces ..... 12
- The Charms Bar ..... 12
- Shutting down the computer ..... 12
- Switching between apps ..... 13
- Closing an app ..... 13
- Opening other system programs ..... 13
- Windows Help and Support ..... 13

### **Using the Rescue System..... 15**

- OneKey Recovery ..... 16
- Driver and Application Installation ..... 17

### **Using the Software..... 19**

- Lenovo Support .....20

<b>Troubleshooting and Confirming Setup .....</b>	<b>21</b>
Troubleshooting Display Problems .....	22
Troubleshooting Audio Problems .....	23
Troubleshooting Software Problems .....	24
Troubleshooting Problems with Optical Drives and Hard Disks .....	24
Special considerations for troubleshooting Windows .....	25
Windows Help and Support .....	26
Performing Daily Maintenance Tasks .....	26
 <b>Hardware Replacement Guide .....</b>	 <b>29</b>
Locations .....	33
Replacing hardware .....	35
 <b>Appendix. ....</b>	 <b>47</b>
Declaration .....	47
Trademarks .....	48
Energy Star Statement .....	49
Enabling ErP compliance mode.....	50

# Using the Computer Hardware

---

## This chapter contains the following topics:

- Introduction to the computer hardware
- Information on computer connections

 **Note:** The descriptions in this chapter might be different from what you see on your computer, depending on the computer model and configuration.

# Front view of the chassis



Attention: Be careful not to block any air vents on the computer. Blocked air vents can cause overheating.

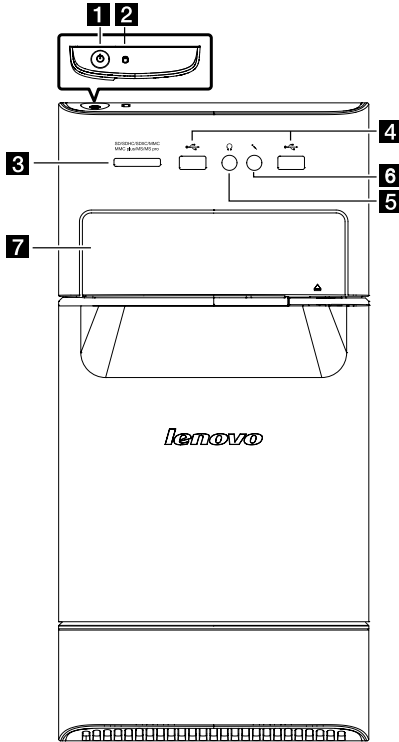

- 1** Power button
- 2** Hard disk drive indicator
- 3** Memory card reader (selected models only)
- 4** USB connectors
- 5** Headphone connector
- 6** Microphone connector
- 7** Optical Drive (selected models only)

# Rear view of the chassis

(If the rear view configuration shown in this chapter is different from the rear of your computer, please refer to the rear of your computer.)

Lenovo H500

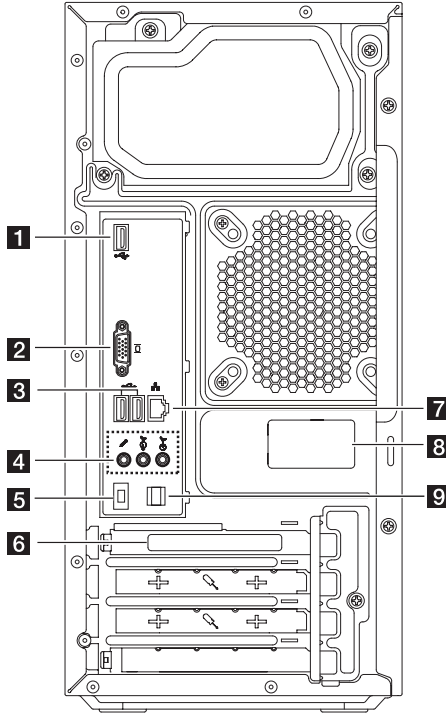

- 1** USB 3.0 connector
- 2** On-board VGA connector
- 3** USB 2.0 connectors (2)
- 4** Audio connectors
- 5** Power connector
- 6** PCI Express X 16 graphics adapter slot (some models are equipped with a graphics card)
- 7** Ethernet connector
- 8** WiFi antenna (selected models only)
- 9** Cable clip



**Note:** If your model has two VGA monitor connectors, be sure to use the connector on the graphics adapter.



**Attention:** Do not open the WiFi antenna cover.

## Basic connector instructions



**Note:** Your computer may not have all of the connectors described in this section.

Connector	Description
Microphone	Use this connector to attach a microphone to your computer when you want to record sound or if you use speech-recognition software.
Headphone	Use this connector to attach headphones to your computer when you want to listen to music or other sounds without disturbing anyone.
Audio line-in connector	Used to receive audio signals from an external audio device, such as a stereo system. When you attach an external audio device, a cable is connected between the audio line-out connector of the device and the audio line-in connector of the computer.
Audio line-out connector	Used to send audio signals from the computer to external devices, such as powered stereo speakers (speakers with built-in amplifiers), headphones, multimedia keyboards, or the audio line-in connector on a stereo system or other external recording device.
Memory card reader	Use to view and share digital photos, music, and videos, stored on a media card.
Power connector	Connect to the power cable. The appearance of this connector may vary.
USB connector	Use this connector to attach a device that requires a USB connection.
Ethernet connector	Use this connector to attach the computer to an Ethernet-type local area network.
VGA connector	Used to attach a VGA monitor or other devices that use a VGA monitor connector.

DVI connector	Used to attach a DVI monitor or other devices that use a DVI monitor connector.
HDMI connector (optional)	Connect to the HDMI connector on your display or TV.
TV-Tuner connector (optional)	Only supported on systems with an optional TV tuner card.

**!** **Note:** If your computer is equipped with a wireless keyboard or mouse, follow the installation instructions for those devices.

## Connecting your computer

Use the following information when connecting your computer.

- Look for the small connector icons on the back of your computer. Match the connectors to the icons.
- If your computer cables and connector panel have color-coded connectors, match the color of the cable end with the color of the connector.

**!** **Note:** Your computer may not have all of the connectors described in this section.

**Check the position of the voltage-selection switch on the rear of the computer. Use a ballpoint pen to slide the switch if necessary.**

**!** **Note:** Some computers do not have a voltage switch. These computers control voltage automatically.

- If the voltage supply range is 100-127 V AC, set the switch to 115 V.
- If the voltage supply range is 200-240 V AC, set the switch to 230 V.

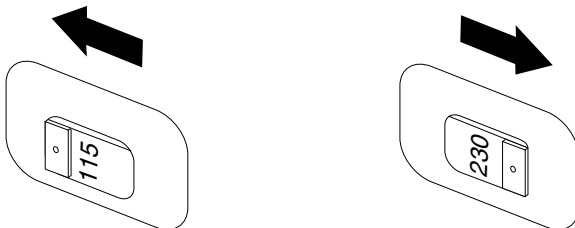

# 5.1 Audio configuration instructions

This model of computer supports the transformation of stereo sound into 5.1 surround sound.

Use the following guides when connecting to the 5.1 surround audio device:

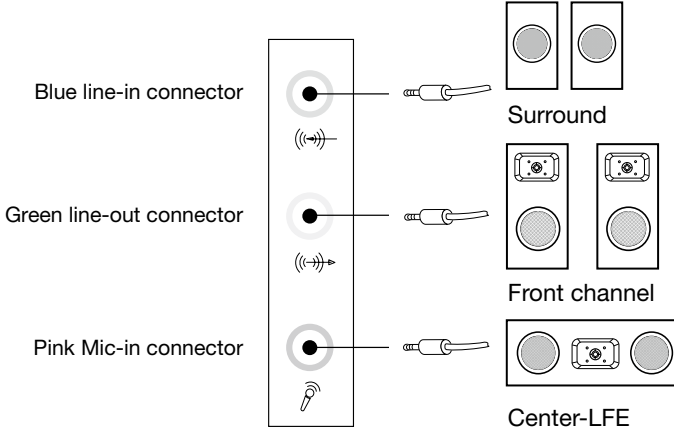

## The configurations are as followings:

1. Right click the **Sound** icon in system property bar and select **Playback devices** option to setup the sounds in the pop-up dialog box.
2. Select a playback device from the **Playback** dialog box, then click the **Configure** button to configure it.
3. Select **5.1 surround** from audio channels in the pop-up **Speaker setup** dialog box to proceed with the speaker setup by following the prompts.
4. 5.1 surround sound can be used once this configuration procedure is complete.

**!** **Note:** If the audio configuration interfaces above are different from those on your computer, you may use the above steps as a reference to configure the 5.1 surround sound audio device system in your actual audio configuration interface and read the electronic Help information for further assistance.

# Connecting the power cord

Connect the power adapter to an electrical outlet. We recommend using a grounded connection or a surge protector.

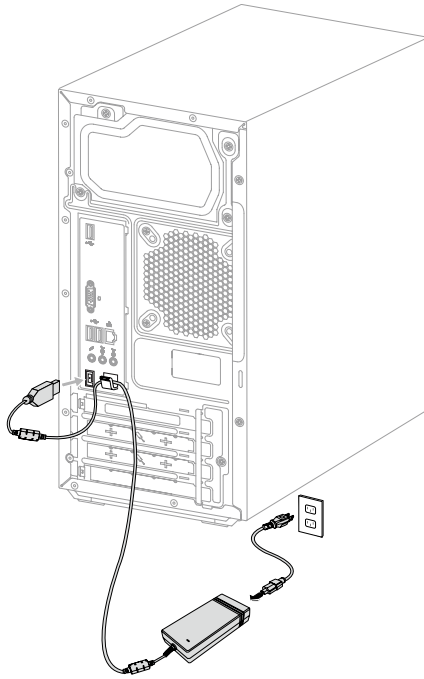







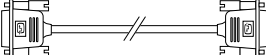

# Display connecting instructions when playing Blu-ray Discs

**!** **Note:** Only some models are equipped with Blu-ray optical drive.

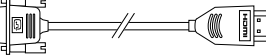
Check the connectors available on your computer and display and select an appropriate cable according to the table below. Other types of cables do not meet the requirements of the Blu-ray standard.

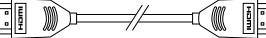
You need to purchase the cable separately if the computer is not equipped with the corresponding cable.

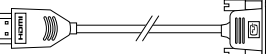
This table will help you to identify the connectors on your computer and display.

Connection Type	Computer	Cable	Display
DVI to DVI (DVI cable)			
DVI to HDMI (DVI-HDMI cable)			
HDMI to HDMI (HDMI cable)			
HDMI to DVI (HDMI-DVI cable)			

## Connecting to the Internet

To connect to the Internet, you'll need a contract with an Internet Service Provider (ISP) and some hardware.

IPs and ISP offerings vary by country. Contact your ISP for offerings available in your country.

Your computer is designed to support a wireless (selected models only) or wired network that connects your computer to other devices.

### Wired network connection

For wired networks, connect one end of an Ethernet cable (purchased separately) to the Ethernet connector on your computer, and then connect the other end to the network router or broadband modem. Consult your ISP for detailed setup instructions.

**!** **Note:** Broadband modem and router installation procedures vary depending on the manufacturer. Follow the manufacturer's instructions.

## Wireless network connection

For wireless networks, you can use the built-in wireless LAN antenna to access your wireless home network.

To connect your computer to the wireless network:

1. Move the cursor to the top right or bottom right corner of the screen, then click **Settings**. (If your computer is equipped with touch screen, swipe in from the right edge of the screen, then tap **Settings**.)
2. Click or tap the network icon , then select the name of your router. Click or tap **Connect**, then follow the steps on the screen.

Test the wireless network by opening your Web browser and accessing any Web site.

## Wired keyboard (selected models only)

**LVT** — After entering Windows, press this key to launch the LVT (Lenovo Vantage Technology) program, Lenovo's pre-loaded Home PC software. In addition to its own functions, the LVT program will allow you to start other Windows compatible software specially configured to run on this model of computer.

### **Notes:**

- Some models are not equipped with the LVT program.
- The LVT key on the keyboard is disabled in the models without the LVT program.

**F2** — Your computer has the Lenovo Rescue System installed. To learn more about this program, repeatedly press and release the F2 key once turning on the computer until the Lenovo Rescue System opens.



# Using Windows 8

---

## This chapter contains the following topics:

- Switching between the main Windows 8 interfaces
- The Charms Bar
- Shutting down the computer
- Switching between apps
- Closing an app
- Opening other system programs
- Windows Help and Support



**Attention:** The Windows 8 operating system is provided by Microsoft Corporation. Please use it in accordance with the END USER LICENSE AGREEMENT (EULA) between you and Microsoft. For any question related to the operating system, please contact Microsoft directly.

# Switching between the main Windows 8 interfaces

Windows 8 comes with two main user interfaces: the Start Screen and the Windows desktop.

To switch from the Start Screen to the Windows desktop, do one of the following:

- Select the Windows desktop tile on the Start Screen.
- Press the Windows key  + D.

To switch from the desktop to the Start Screen, do one of the following:

- Select **Start** from the Charms Bar.
- Move the cursor to the bottom left corner, then select the Start Screen thumbnail when it is displayed.
- Press the Windows key .

## The Charms Bar

Charms provide new and faster ways to perform many basic tasks.

To display the charms, do one of the following:

- Move the cursor to the top right or bottom right corner of the screen.
- If your computer is equipped with touch screen, swipe in from the right edge of the screen.
- Press the Windows key  + C.

## Shutting down the computer

To shut down the computer:

1. Move the cursor to the top right or bottom right corner of the screen, then click **Settings**. (If your computer is equipped with touch screen, swipe in from the right edge of the screen, then tap **Settings**.)
2. Select **Power** → **Shutdown**.

## Switching between apps

Sometimes you want to get back to an app you were just using, or quickly switch through your recent apps.

To switch between apps:

Move the cursor to the top left corner, then click to bring in the next app. (If your computer is equipped with touch screen, swipe in from the left edge of the screen to bring in the next app.)

## Closing an app

To close an app, do one of the following:

- Move the cursor to the top left corner of the screen. When the thumbnail appears, drag it to the bottom of the screen.
- Move the cursor to the top edge of the screen. When the cursor becomes a hand, drag the app page to the bottom of the screen.
- If your computer is equipped with touch screen, swipe in from the top edge of the screen. When the app page becomes smaller, drag it to the bottom of the screen.

## Opening other system programs

There is a fast way to open other system programs.

To open the menu, do one of the following:

- Move the cursor to the bottom left corner of the screen. When the thumbnail appears, right-click with the mouse to open the menu.
- Press the Windows key  + X.

## Windows Help and Support

If you have a problem with the operating system, see the Windows Help and Support file. To open the Windows Help and Support file, do one of the following:

- Select the **Settings** charm, then select **Help**.
- Press the Windows key  + F1.

You can read the Windows Help and Support file on your computer. You can also get online help and support by clicking on one of the two links listed under **More to explore**.



# Using the Rescue System

---

## This chapter contains the following topics:

- OneKey Recovery
- Driver and Application Installation



**Attention:** Using OneKey Recovery will result in loss of data.

- You can restore the C: drive of the computer to factory default settings or to the last system backup status using **OneKey Recovery**. If you do this, all of the existing data on drive C: will be lost, but the content and format of the other partitions of the hard disk drive will remain unchanged.
- If you want to install an operating system and back it up with **OneKey Recovery**, you must format the C: partition in **NTFS** format and install the operating system on the C: partition. Otherwise, the **OneKey Recovery** system cannot run.

## Note about the service partition:

The files and relevant data used by the rescue system are saved in the service partition. Deleting this partition will make the rescue system unusable. For more detailed information, see the following instructions:

From the **Search** charm, select **Apps** → **Control Panel** → **Administrative Tools** → **Computer Management** → **Disk Management**, you can see the service partition, which must not be deleted.

 **Note:** The recovery files and relevant data used by the rescue system are saved in the service partition. If the service partition is deleted or damaged by someone other than authorized Lenovo service personnel, Lenovo will not be liable for any losses arising therefrom in any way.

## OneKey Recovery

**OneKey Recovery** is an easy-to-use application. You can use it to restore your computer to the system default or to a previously backed up state.

### Detailed Operation Procedure

1. Repeatedly press and release the **F2** key once turning on the computer until the **Lenovo Rescue System** opens, then select **OneKey Recovery**.

 **Note:** System Recovery will overwrite all of the data on the C: drive. To prevent loss of data, be sure to back up relevant data before performing system recovery.

2. Follow the on-screen instructions to select the backup task you want to restore from and the disk where you want to install the operating system, then press **Next** to start the restore.
3. Please wait during the process of system recovery. Do not interrupt the operation during the recovery process.
4. After the system is recovered successfully, the software will prompt you to restart the computer. Restart the computer and start the operating system.

# Driver and Application Installation

The **Driver and Application Installation** function in the rescue system provides a way for the user to conveniently reinstall all of the Lenovo applications and drivers that were shipped with your Lenovo hardware.

## Method 1: Automatic Installation

Repeatedly press and release the **F2** key once turning on the computer until the **Lenovo Rescue System** opens, then select **Driver and Application Installation**.

Follow the on-screen prompts to install the Lenovo drivers and applications. Click **OK** to start installing the **Lenovo Driver and Application Installation** software.

The system will restart. After the system has restarted, the drivers and application installation process will continue until it has completed.

## Method 2: Manual Installation

In the Windows system, Select **Driver and Application Installation** from the **Search** charm.

After starting the procedure, install the drivers and software manually by following the prompts.



### Notes:

1. Do not install software which is already installed on the computer.
2. Make sure that the Driver and Application Installation software has been automatically installed before starting the operating system. The manual installation function can only be used after the software has been installed.



# Using the Software

---



## **This chapter contains the following topic:**

- Software instructions

 **Note:** The interface and functionality of these features will depend on which software was shipped with the computer model you purchased.

# Lenovo Support

The Lenovo Support program enables you to register your computer with Lenovo, download and view user manuals for your computer, get the warranty information of your computer, and explore help and support information.

## **To open this program, do the following:**

Click the Lenovo Support icon from the Start Screen or Search Screen.

**The main functions of this program are listed below.** (This program supports online upgrades. The functions shown below are for reference only, functionality will depend on the program icons currently displayed.)

## Registration

Registration provides you with access to product support, upgrades and alerts on topics. Take advantage of award-winning Lenovo services.

## User Guide

The User Guide provides more information about your computer.

## Service and Warranty

You can extend the warranty of your computer through this option. Lenovo provides flexible options to meet your personal or business needs.

# Troubleshooting and Confirming Setup

---

A graphic of a spiral-bound notebook with a white cover and a silver spiral binding on the left side. The notebook is open to a page with a white background and a thin black border. The text is printed on this page.

**This chapter contains the following topic:**

- Troubleshooting and Problem Resolution

# Solving Problems

## Follow these tips when troubleshooting your computer:

- If you added or removed a part before the problem started, review the installation procedures to ensure that the part is correctly installed.
- If a peripheral device does not work, ensure that the device is properly connected.
- If an error message appears on the screen, write down the exact message. This message may help support personnel diagnose and fix the problem(s).
- If an error message occurs in a program, see the Help document of this program.

## Troubleshooting Display Problems

**Problem:** Blank screen or no image is displayed on the monitor.

### Troubleshooting and problem resolution:

1. Check to see if the monitor has been turned on; if not, press the Power button.
2. Check to see if the monitor power cord is loose; if so, plug the power cord securely into the monitor.
3. Check to see if the signal cable to the monitor is securely connected to the connector on the computer graphics card; if not, shut down the computer then connect the signal cable of the monitor securely to the connector on the computer graphics card.

**Problem:** You need to change the display property settings.

### Setting display background and icon properties:

1. Right-click the desktop anywhere except over an icon, then select Personalize from the pop-up menu.
2. From here, select the appropriate options to:
  - Change the desktop background
  - Select a screen saver
  - Select Windows color options for borders and taskbar
  - Select a themes
3. Right-click the desktop anywhere except over an icon, then select Screen resolution from the pop-up menu to change the appearance.

**Problem:** Ripple on screen.

**Troubleshooting and problem resolution:**

1. Check to see if any of the following devices are located less than one meter from the computer: refrigerators, electric fans, electric dryers, UPS systems, regulators, fluorescent lamps or other computers that may be generating magnetic interference.
2. Move any interfering devices away from the computer.
3. If the problem persists, contact Lenovo Service.

## Troubleshooting Audio Problems

**Problem:** No sound from the integrated speakers.

**Troubleshooting and problem resolution:**

- Adjust the Windows volume control — select the speaker icon from the **Settings** Charm or click the arrow on taskbar to show the hidden icons in Windows desktop mode, then click the speaker icon. Ensure that the volume is turned up and the sound is not muted. Adjust the volume, bass, or treble controls to eliminate distortion.
- Reinstall the audio driver.
- Disconnect any headphones from the headphone connector — sound from the speakers is automatically disabled when headphones are connected to the computer's side-panel headphone connector.

**Problem:** No sound from headphones.

**Troubleshooting and problem resolution:**

- Check the headphone cable connection — ensure that the headphone cable is securely inserted into the headphone connector.
- Adjust the Windows volume control — select the speaker icon from the **Settings** Charm or click the arrow on taskbar to show the hidden icons in Windows desktop mode, then click the speaker icon. Ensure that the volume is turned up and the sound is not muted.

# Troubleshooting Software Problems

**Problem:** You are unable to exit a running program normally.

**Troubleshooting and problem resolution:**

1. Press the **Ctrl**, **Alt** and **Delete** keys at the same time, then select the **Task Manager** option from the pop-up dialog box.
2. Select the problem program, then click the **End Task** button.

**Problem:** You need to install or uninstall a program.

**Problem resolution:**

*During installation* never abort the install process by powering the system off or through other drastic means. This can cause system program problems or even failure during system initialization.

*During the uninstall process*, never directly delete the files or folders. This is harmful to the operating system, and might cause a system-wide malfunction. Use the following procedure to properly uninstall programs:

1. Back up all documents and system settings related to the program before removing it.
2. If the program has its own uninstaller, run it directly to uninstall the program.
3. If the program does not have its own uninstaller, then select **Apps** → **Control Panel** from the **Search** charm.
4. From the **Control Panel**, choose **Programs** → **Programs and Features**.
5. Find the applicable program from the **Programs and Features** dialog box and then select **Uninstall/Change**.
6. Perform the instructions displayed to uninstall the software.

# Troubleshooting Problems with Optical Drives and Hard Disks

**Problem:** The Optical drive is unable to read a CD/DVD.

**Troubleshooting and problem resolution:**

1. Check to determine if there is an optical drive icon in the resource manager of the operating system. If not, restart your computer. If there is still no icon, contact Lenovo Service. Otherwise, continue with the next step of this procedure.

2. Confirm that the CD/DVD has been properly placed in the drive. If not, reload the CD or DVD. Otherwise, continue with the next step of this procedure.
3. Check the specifications that came with your computer to confirm that this optical drive is capable of reading this type of CD or DVD.
4. If the CD/DVD cannot be read, replace it with a known good CD/DVD such as one that was shipped with the computer.
5. If the known good CD cannot be read, visually check the operating side of the CD/DVD for defects.

**Problem:** The capacity of the hard disk, as indicated by the system, is less than the nominal capacity.

**Troubleshooting and problem resolution:** For computers equipped with the OneKey Recovery feature, the system recovery feature needs to occupy some hard disk space. This may account for the apparent hard disk capacity deficit.

**Further Technical Explanation:** The nominal capacity of the hard disk is expressed in the decimal system as 1000 bytes. But the actual hard disk capacity is expressed in the binary system as 1024 bytes (For example, the nominal capacity 1G is 1000M, while the actual capacity 1G is 1024M).

The capacity of the hard disk shown in Windows can be calculated according to the calculations in the following example:

The nominal capacity of the hard disk is 40G, while its actual capacity should be:  $40 \times 1000 \times 1000 \times 1000 / (1024 \times 1024 \times 1024) = 37\text{G}$ .

If the Service partition of 3G -  $3 \times 1000 \times 1000 \times 1000 / (1024 \times 1024 \times 1024) = 2.79\text{G}$  is subtracted, the capacity of the hard disk shown in the system can be obtained.

The capacity of the hard disk as calculated using this method may be slightly different from the actual capacity due to the rounding of totals.

## Special considerations for troubleshooting Windows

Record the following information as it may be useful later when troubleshooting system problems:

The drivers for this computer model only support the Windows 8 system.

# Windows Help and Support

If you have a problem with the operating system, see the Windows Help and Support file. To open the Windows Help and Support file, do one of the following:

- Select the **Settings** charm, then select **Help**.
- Press Windows key  + F1.

You can read the Windows Help and Support file on your computer. You can also get online help and support by clicking on one of the two links listed under **More to explore**.

## Performing Daily Maintenance Tasks

### Cleaning the computer components

Because many of the computer components consist of sophisticated integrated circuit boards, it is very important to periodically clean the computer to prevent dust buildup. The cleaning supplies you need to clean the components include: a vacuum cleaner, a soft cotton cloth, pure water (preferably purified or distilled water) and cotton swabs.



**Attention:** Before you clean your computer, disconnect the computer from the electrical outlet. Clean your computer with a soft cloth dampened with water. Do not use liquid or aerosol cleaners, which may contain flammable substances.



**Note:** To avoid damaging the computer or display, do not spray cleaning solution directly onto the display. Only use products specifically designed for cleaning displays, and follow the instructions included with the product.

### The following are general methods for cleaning the components:

- You can use a soft cloth to remove dust on the surface of the computer, the monitor, the printer, the speakers and the mouse.
- You can use a vacuum cleaner to clean in otherwise inaccessible corners.
- To clean the keyboard thoroughly, shut down the computer and scrub it gently with a wet cloth. Do not use the keyboard until it is dry.

**Do not do any of the following:**

- Allow water to enter the computer.
- Use a heavily dampened cloth.
- Spray water directly onto the surface of the monitor or inside the computer.

LCD monitor should be cleaned daily. Use a dry cloth to brush dust from the monitor and keyboard every day. Keep all surfaces clean and free of grease stains.



# Hardware Replacement Guide

---



**This chapter contains the following topics:**

- Locating components
- Identifying parts on the system board
- Removing the computer cover
- Removing and replacing the front bezel
- Replacing a memory module
- Replacing the hard disk drive
- Replacing an optical drive
- Replacing a PCI express adapter
- Replacing the keyboard and mouse
- Completing the installation

# Overview

This guide is intended to be used by customers who are replacing Customer Replaceable Units (CRUs) as well as trained service personnel who are replacing Field Replaceable Units (FRUs). In this guide, CRUs and FRUs will be referred to as parts.

 **Note:** Trained service personnel should refer to the *Hardware Maintenance Manual (HMM)* for parts ordering information.

This guide does not include procedures for all parts. It is expected that cables, switches, and certain mechanical parts can be replaced by trained service personnel without the need for step-by-step procedures.

 **Note:** Use only parts provided by Lenovo™.

The description of the TV card in this manual applies only to machines which have a TV card. It does not apply to machines which do not have a TV card.

This guide contains procedures for replacing the following parts:

- Memory modules
- Hard disk drive
- Optical drive
- Graphic Card
- Card reader module
- Keyboard
- Mouse

## Safety information for replacing CRUs

Do not open your computer or attempt any repair before reading the “Important safety information” in the *Safety and Warranty Guide* that was included with your computer. If you no longer have this copy of the *Safety and Warranty Guide*, you can obtain one online from the Support Web site at <http://support.lenovo.com>.

## Additional information resources

If you have Internet access, the most up-to-date information for your computer is available from the World Wide Web.

You can find the following information:

- CRU removal and installation information
- Publications
- Troubleshooting information
- Parts information
- Links to other useful sources of information

To access this information, go to <http://support.lenovo.com>.

## Tools required

To disassemble the computer, you need the following tools:

- Wrist grounding strap and conductive mat for preventing electrostatic discharge
- Flat screwdriver
- Phillips screwdriver
- Hex screwdriver
- Plastic flat screwdriver
- Plastic tweezers



**Note:** The screws for the different components vary in size. During the disassembly procedure, group the screws with their corresponding components to avoid a mismatch when replacing the components.

## Handling static-sensitive devices

Static electricity is harmless to you, but it can seriously damage computer components.

When you are replacing a part, do *not* open the antistatic package containing the new part until the defective part has been removed from the computer and you are ready to install the new part.

Take these precautions to avoid static electricity damage when handling parts and other computer components:

- Limit your movement. Movement can cause static electricity to build up around you.
- Always handle parts and other computer components carefully. Handle adapters, memory modules, system boards, and microprocessors by the edges. Never touch any exposed circuitry.
- Prevent others from touching the parts and other computer components.
- Before you replace a new part, touch the antistatic package containing the part to a metal expansion slot cover or other unpainted metal surface on the computer for at least two seconds. This reduces static electricity in the package and your body.
- When possible, remove the new part from its antistatic packaging and install it directly into the computer without setting the part down. When this is not possible, place the antistatic package that the part came in on a smooth, level surface and place the part on it.
- Do not place the part on the computer cover or other metal surface.

# Locations

This section provides illustrations to help locate the various connectors, controls and components of the computer. To remove the computer cover, refer to “Removing the computer cover”.

## Locating components

The following illustration will help you to locate the various components in your computer.

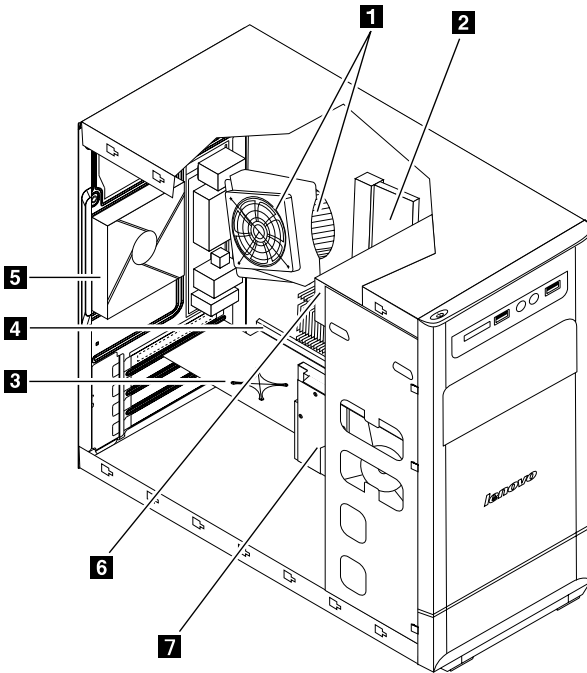

- |  |   |
|--|---|
| <b>1</b> Microprocessor fan and heatsink | <b>2</b> Memory modules                 |
| <b>3</b> PCI express adapter card        | <b>4</b> PCI express adapter connectors |
| <b>5</b> System fan                      | <b>6</b> Optical drive                  |
| <b>7</b> Hard disk drive                 |   |

# Identifying parts on the system board

The system board (sometimes called the motherboard) is the main circuit board in your computer. It provides basic computer functions and supports a variety of devices that are factory-installed or that you can install later.

The following illustration shows the locations of parts on the system board.

Lenovo H500

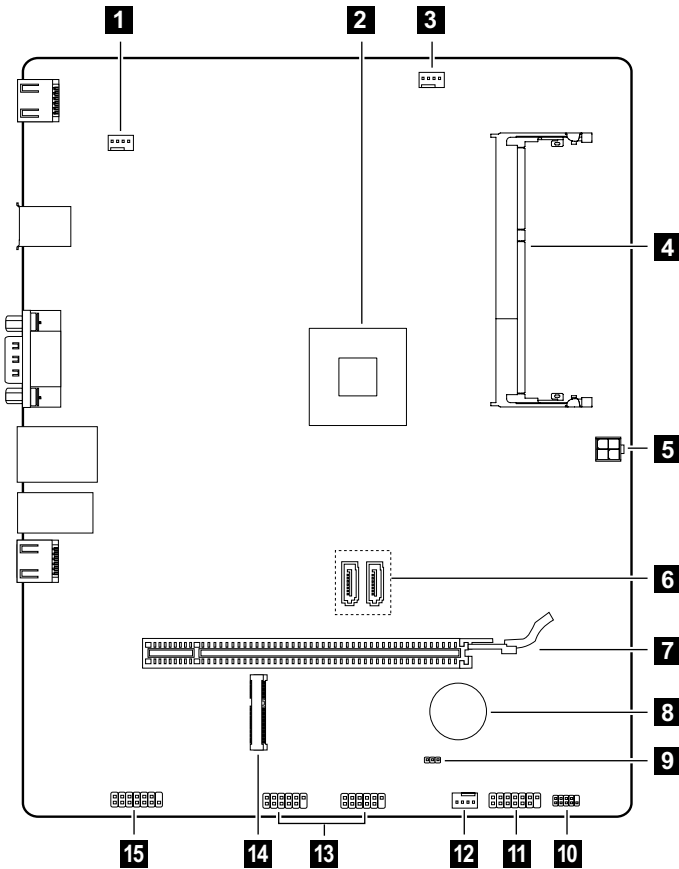

- |  |                              |
|--|------------------------------|
| <b>1</b> System fan header               | <b>2</b> Microprocessor      |
| <b>3</b> Microprocessor fan header       | <b>4</b> Memory slot         |
| <b>5</b> Hard disk drive power connector | <b>6</b> SATA connectors (2) |
| <b>7</b> PCI express X 16 adapter slot   | <b>8</b> Battery             |

- |           |                          |           |                   |
|-----------|--------------------------|-----------|-------------------|
| <b>9</b>  | Clear CMOS jumper        | <b>10</b> | LPC debug header  |
| <b>11</b> | Front panel connector    | <b>12</b> | System fan header |
| <b>13</b> | Front USB connectors (2) | <b>14</b> | Mini PCI-E slot   |
| <b>15</b> | Front audio connector    |           |                   |

## Replacing hardware

 **Note:** Use only parts provided by Lenovo.

### Removing the computer cover



**Attention:** Turn off the computer and wait three to five minutes to let it cool down before removing the cover.

#### To remove the computer cover:

1. Remove any media (disks, CDs, or memory cards) from the drives, shut down the operating system, and turn off the computer and all attached devices.
2. Unplug all power cords from electrical outlets.
3. Disconnect all cables attached to the computer. This includes power cords, input/output (I/O) cables, and any other cables that are connected to the computer. Refer to “Locating connectors on the rear of the computer”.
4. Remove the two screws that secure the computer cover at the rear of the chassis.

5. Slide the computer cover to the rear of the chassis to remove it.

**!** **Note:** For this procedure, it helps to lay the computer on its side.

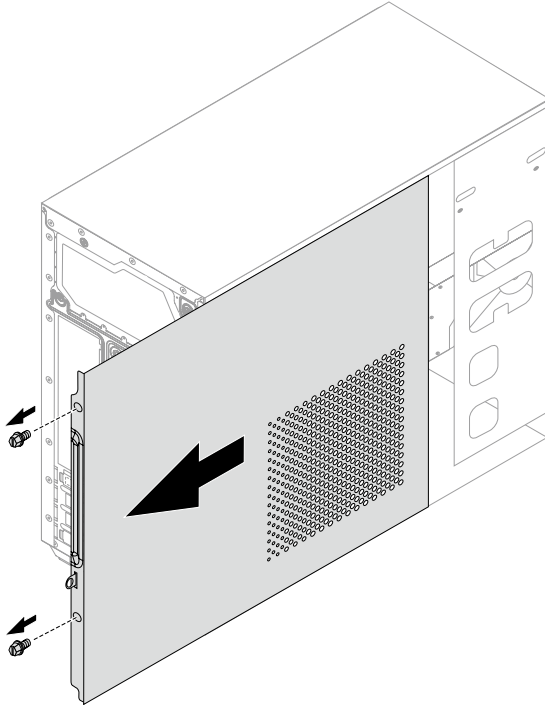

# Removing and replacing the front bezel

## To remove and replace the front bezel:

1. Remove the computer cover. Refer to “Removing the computer cover”.

**!** **Note:** For this procedure, it helps to lay the computer on its side.

2. Remove the front bezel by releasing the three plastic tabs inside the chassis and pushing the bezel outward as shown.

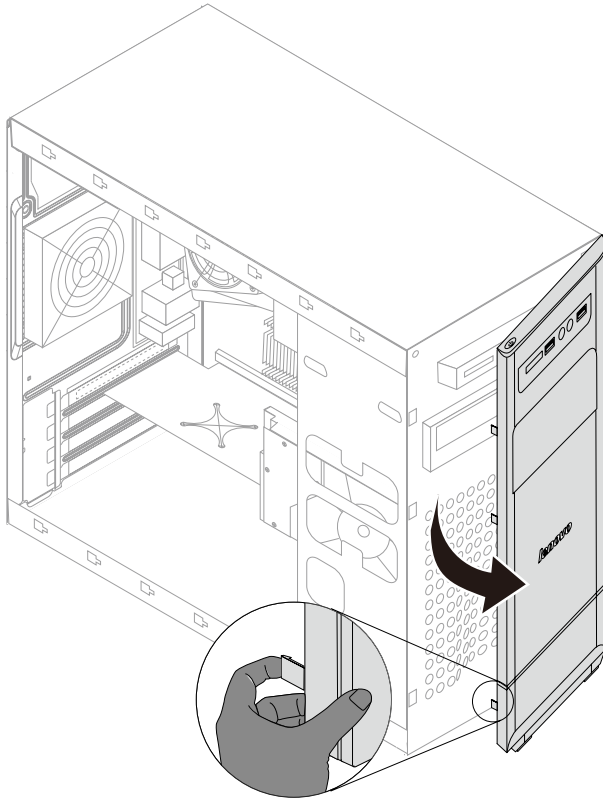

3. To reinstall the bezel, align the plastic tabs on the bottom of the bezel with the corresponding holes in the chassis, then snap them into position at the bottom and top.
4. Refer to “Completing the installation”.

# Replacing a memory module

## To replace a memory module:

1. Remove the computer cover. Refer to “Removing the computer cover”.
2. Locate the memory module connectors. Refer to “Locating components”.
3. Remove the memory module being replaced by opening the retaining clips as shown.

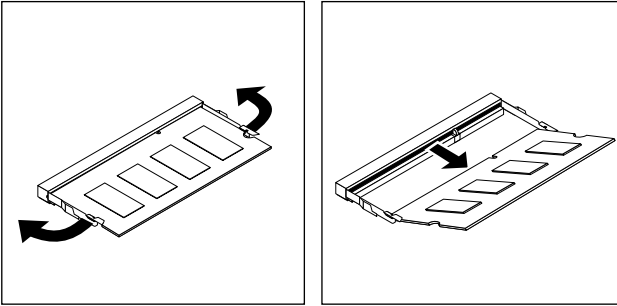

4. Insert the notched end **1** of the new memory module into the slot. Press the memory module firmly and pivot the memory module until it snaps into place. Make sure that the memory module is secured in the slot and does not move easily.

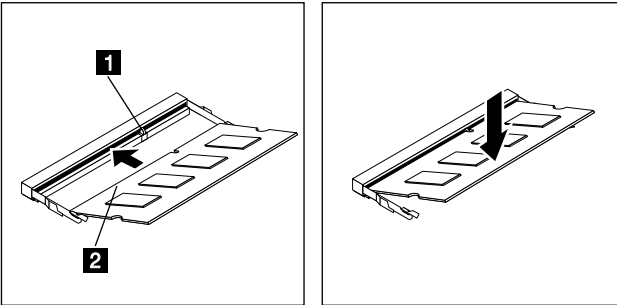

5. Refer to “Completing the installation”.

# Replacing the hard disk drive

## To replace the hard disk drive:

1. Remove the computer cover. Refer to “Removing the computer cover”.

**!** **Note:** For this procedure, it helps to lay the computer on its side.

2. Disconnect the data and power cables from the hard disk drive. **1**
3. Remove the four screws that secure the hard disk drive to drive bay. **2**
4. Remove the hard disk drive by pulling it straight out of the drive bay. **3**

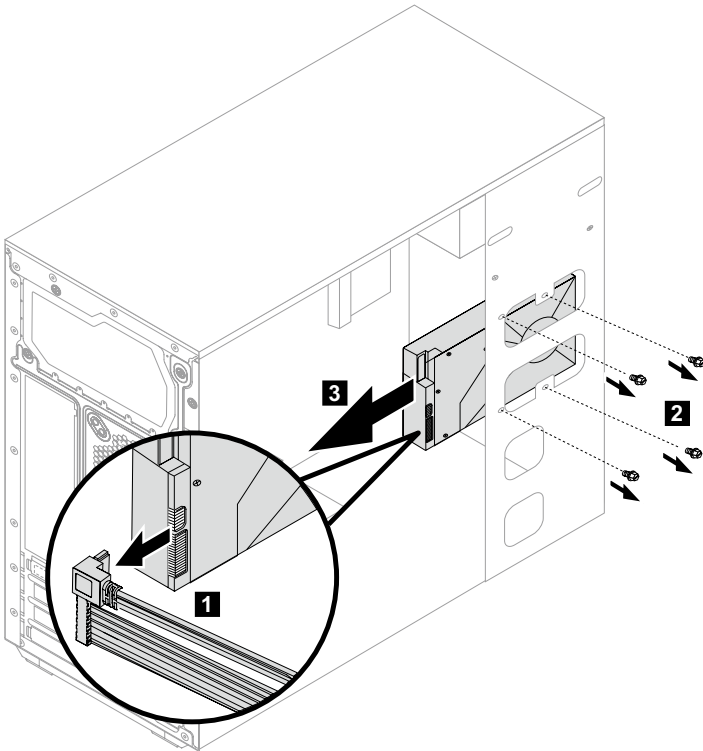

5. Slide the new hard disk drive into the drive bay.
6. Secure the new hard disk drive to the drive bay with the four screws.
7. Connect the power and data cables to the hard disk drive. Refer to “Identifying parts on the system board”.
8. Refer to “Completing the installation”.

# Replacing an optical drive

## To replace an optical drive

1. Remove the computer cover. Refer to “Removing the computer cover”.
2. Remove the front bezel. Refer to “Removing and replacing the front bezel”.
3. Disconnect the data and power cables from the rear of the optical drive.
4. Remove the two screws that secure the optical drive to drive bay. **1**
5. Push the optical drive straight out of the front of the chassis. **2**

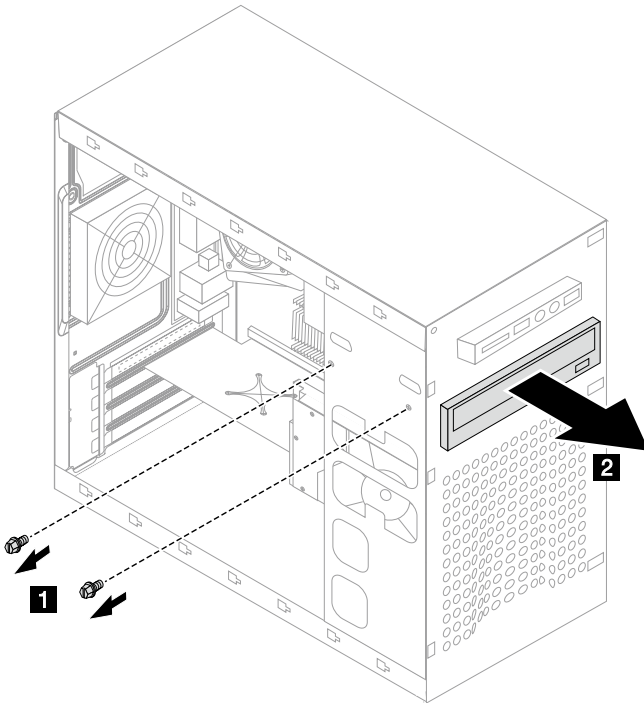

6. Slide the new optical drive into the bay from the back until it snaps into position.
7. Secure the optical drive to the bay with the two screws.
8. Connect the data and power cables to the drive.
9. Install the front bezel. Refer to “Removing and replacing the front bezel”.
10. Refer to “Completing the installation”.

# Replacing the card reader module

## To replace the card reader module

1. Remove the computer cover. Refer to “Removing the computer cover”.
2. Remove the front bezel. Refer to “Removing and replacing the front bezel”.
3. Disconnect the card reader data cable from the connector on the motherboard.
4. Remove the screw that secures the card reader module to the chassis.
5. Slide out the card reader module as show.

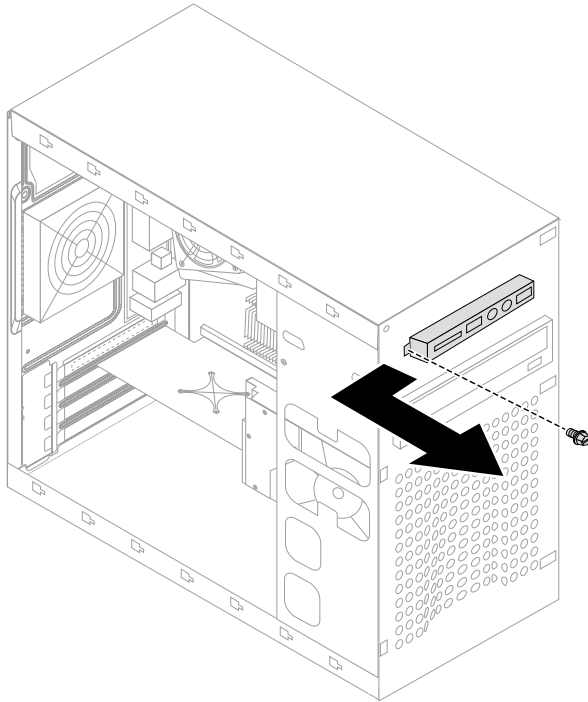

6. Line up the new card reader module with the mounting hole on the chassis, then slide it into position.
7. Secure the new card reader module to the chassis with the screw.
8. Install the front bezel. Refer to “Removing and replacing the front bezel”.
9. Refer to “Completing the installation”.

# Replacing a PCI express adapter

## To replace an adapter:

1. Remove the computer cover. Refer to “Removing the computer cover”.
2. Remove the screw that secures the latch to the chassis, **1** open the adapter latch **2** and remove the adapter by pulling it straight out of the adapter connector. **3**

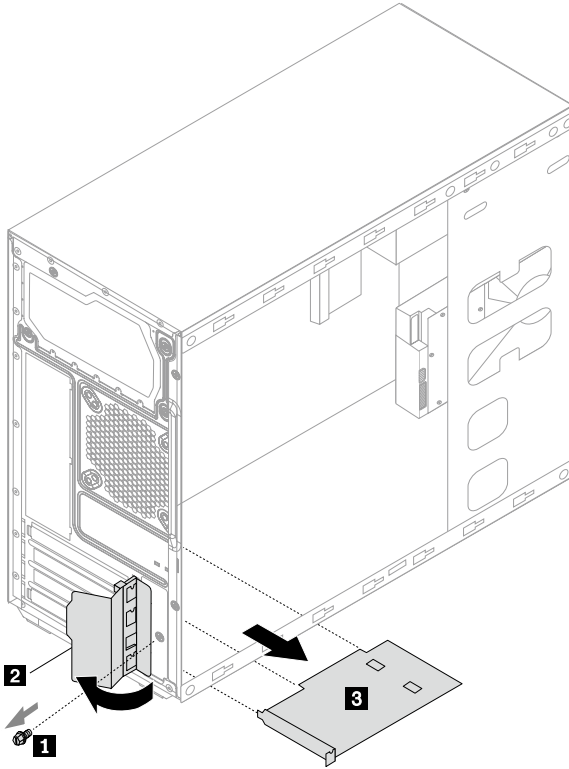

3. Install the new adapter into the same adapter connector.

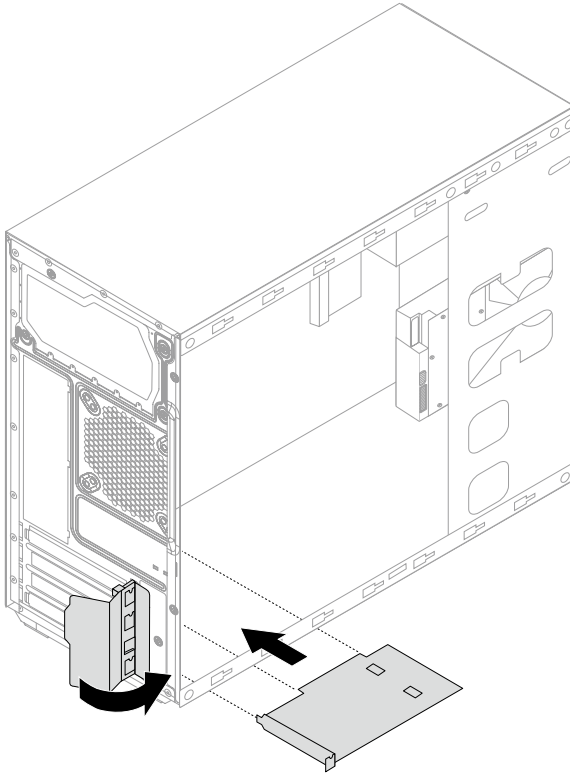

4. Ensure the adapter is fully seated into the adapter connector.
5. Screw the latch into the chassis.
6. Refer to "Completing the installation".

# Replacing the keyboard and mouse

## To replace the keyboard:

1. Remove any media (disks, CDs, or memory cards) from the drives, shut down the operating system, and turn off the computer and all attached devices.
2. Unplug all power cords from electrical outlets.
3. Locate the connector for the keyboard. Refer to “Locating connectors on the rear of the computer” and “Locating connectors on the front of the computer”.



**Note:** Your keyboard will be connected to a USB connector at either front or at the rear of the computer.

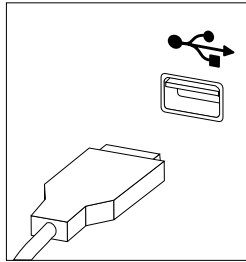

4. Disconnect the failing keyboard cable from the computer and connect the new keyboard cable to the same connector.
  5. Refer to “Completing the installation”.
- \* **The mouse can be replaced using the same method.**

## Completing the installation

After replacing a part or parts, you must close the computer cover and reconnect all the cables, including telephone lines and power cords. Some parts will require confirming updated information in the Setup Utility program. Refer to “Starting the Setup Utility” in the Hardware Maintenance Manual.

### To complete the installation:

1. Ensure that all components have been reassembled correctly and that no tools or loose screws are left inside your computer. Refer to “Locating components” for the location of the various components.
2. Make sure that the cables are routed correctly before replacing the computer cover.
3. Position the computer cover on the chassis so that the rail guides on the bottom of the computer cover engage the rails. Then, push the computer cover closed until it snaps into position. Screw back the two screws on the chassis.

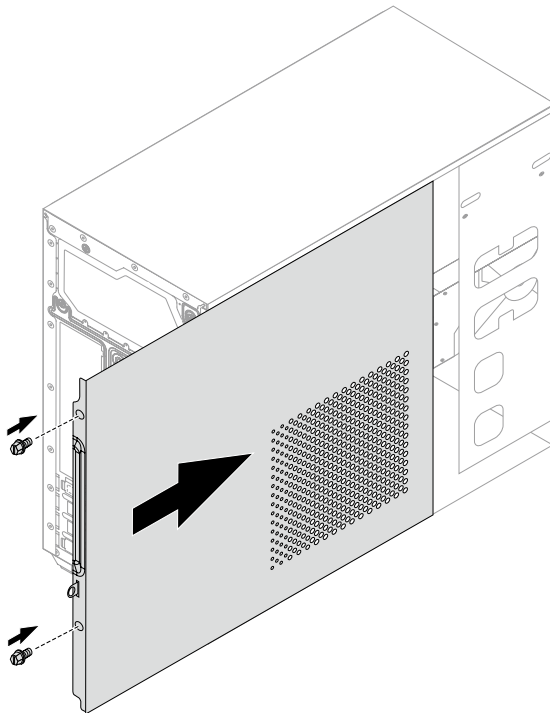

4. Reconnect the external cables and power cords to the computer. Refer to “Locating connectors on the front of the computer” and “Locating connectors on the rear of the computer”.



**Note:** In most areas of the world, Lenovo requires the return of the defective CRU. Information about this will come with the CRU or will come a few days after the CRU arrives.

# Appendix.

## Declaration

Thank you for using Lenovo products.

Carefully read all documents shipped with your computer before you install and use the product for the first time. Lenovo is not responsible for any loss except when caused by installation and operations performed by Lenovo professional service personnel. You are responsible if you fail to operate the product according to instructions and requirements in the manuals included with your computer, or operate the product inappropriately.

This manual could include technical inaccuracies or typographical errors. Changes are made periodically to the information herein; these changes will be incorporated in new editions of the publication. To provide better service, Lenovo reserves the right to improve and/or modify the products and software programs described in the manuals included with your computer, and the content of the manual, at any time without additional notice.

The manuals included with your computer are provided to help you use Lenovo's products appropriately. For the configuration of the product, refer to the related contract (if any) or product packing list, or consult the distributor for the product sales.

The content of the manuals included with your computer is protected by copyright laws and rules. None of the manuals included with your computer may be reproduced or transcribed by any means or translated into any language without prior written permission of Lenovo.

The software interface and function and hardware configuration described in the manuals included with your computer might not match exactly the actual configuration of the computer that you purchase. You are welcome to contact us about the manuals included with your computer. For the latest information or any questions or comments, contact or visit the Lenovo Web site:

Service Web site: <http://support.lenovo.com>

# Trademarks

Lenovo and the Lenovo logo, IdeaCentre and IdeaCentre logo are trademarks of Lenovo in the United States, other countries, or both.

Microsoft, Windows, and Windows Vista are trademarks of the Microsoft group of companies.

Intel Inside is a trademark of Intel Corporation in the U.S. and/or other countries.

AMD, the AMD Arrow logo, ATI, AMD Athlon, AMD LIVE!, AMD Opteron, AMD Phenom, AMD Sempron, Catalyst, Cool 'n' Quiet, CrossFire, PowerPlay, Radeon, and The Ultimate Visual Experience are trademarks of Advanced Micro Devices, Inc.

Other company, product, or service names referred to herein or in other Lenovo publications may be trademarks or service marks of others.

All rights reserved.

Names or marks of certain companies mentioned in the manuals included with your computer or this document do not necessarily indicate that related software or hardware is included. The actual configuration of the product depends on the packing list description.

# Energy Star Statement



ENERGY STAR® is a joint program of the U.S. Environmental Protection Agency and the U.S. Department of Energy aimed at saving money and protecting the environment through energy efficient products and practices.

Lenovo is proud to offer our customers products with an ENERGY STAR compliant designation. The following machine types have been designed and tested to conform to the ENERGY STAR program requirement for computers at the time of manufacture. For more information about ENERGY STAR ratings for Lenovo computers, go to <http://www.lenovo.com>.

- 10156/90AJ

By using ENERGY STAR compliant products and taking advantage of the power-management features of your computer, you reduce the consumption of electricity. Reduced electrical consumption contributes to potential financial savings, a cleaner environment, and the reduction of greenhouse gas emissions.

For more information about ENERGY STAR, go to: <http://www.energystar.gov>.

Lenovo encourages you to make efficient use of energy an integral part of your day-to-day operations. To help in this endeavor, Lenovo has preset the following power-management features to take effect when your computer has been inactive for a specified duration:

ENERGY STAR power-management features, by operating system.

## **Microsoft Windows Vista, Windows 7 and Windows 8**

Power plan: Balanced

- Turn off the display: After 10 minutes
- Put the computer to sleep: After 25 minutes
- Advanced power settings:
  - Turn off hard disk drives: After 20 minutes
  - Hibernate: Never

To awaken your computer from a Sleep or System Standby mode, press any key on your keyboard. For more information about these settings, refer to your Windows Help and Support information system.

# Enabling ErP compliance mode

You can enable the energy-related products directive (ErP) compliance mode through the **Power** menu in the Setup Utility program. This mode reduces electricity consumption when your computer is in standby mode or turned off.

To enable ErP compliance mode in the Setup Utility program, do the following:

1. Repeatedly press and release the F1 key when turning on the computer to start the Setup Utility program.
2. From the Setup Utility program main menu, select **Power** → **ErP** and press Enter.
3. Select **Enabled** and press Enter.
4. Press F10 to save changes and exit the Setup Utility program. Press Enter when prompted to confirm.

 **Note:** When ErP compliance mode is enabled, you only can wake up your computer by pressing the power switch.