

TKRL 660 IX

12NC: 859991635780

GTIN (EAN) code: 8003437625169

Whirlpool

SENSING THE DIFFERENCE

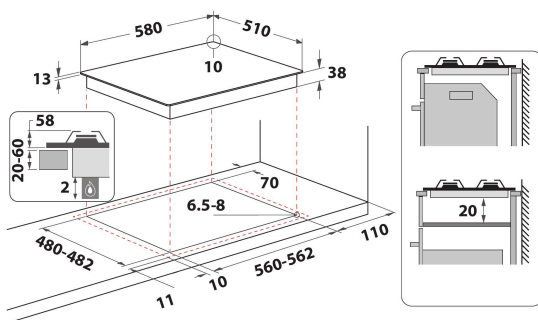

MAIN FEATURES

Product group	Hob
Construction type	Built-in
Type of control	Mechanical
Type of control settings	N/A
Number of gas burners	4
Number of electric cooking zones	0
Number of electric plates	0
Number of radiant plates	0
Number of halogen plates	0
Number of induction plates	0
Number of electric warming zones	0
Location of control panel	Front
Basic surface material	Nerez
Main colour of product	Nerez
Electrical connection rating (W)	0
Gas connection rating (W)	7500
Gas type	G20
Current (A)	0,6
Voltage (V)	230
Frequency (Hz)	50
Length of Electrical Supply Cord (cm)	85
Plug type	Ne
Gas connection	Cilindric
Width of the product	580
Height of the product	40
Depth of the product	510
Minimum niche height	20
Minimum niche width	560
Niche depth	480
Net weight (kg)	10,5
Automatic programmes	Ne

TECHNICAL FEATURES

Power on indicator	Ne
Number of indicators	0
Type of regulation	Rapid
Type of lid	Glass
Residual heat indicator	Without
Main on/off switch	Ne
Safety device	Ano
Timer	Ne

ENERGETICKÝ ŠTÍTEK

Energy input

Plynová