



KI..S..

Built-in appliance

SIEMENS

en Table of Contents

Safety and warning information	3	Freezing and storing food	12
Information concerning disposal	4	Freezing fresh food	12
Scope of delivery	5	Super freezing	13
Room temperature, ventilation and cavity depth	5	Thawing frozen food	14
Installation location	6	Interior fittings	14
Connecting the appliance	6	Sticker "OK"	15
Getting to know your appliance	7	Switching off and disconnecting the appliance	15
Switching the appliance on	8	Defrosting	15
Setting the temperature	8	Cleaning the appliance	16
Holiday mode	8	Odours	17
Alarm functions	9	Light (LED)	17
Usable capacity	9	Tips for saving energy	18
Refrigerator compartment	10	Operating noises	18
Super cooling	11	Eliminating minor faults yourself	19
Freezer compartment	11	Appliance self-test	21
Max. freezing capacity	11	Customer service	21

Safety and warning information

Before you switch ON the appliance

Please read the operating and installation instructions carefully! They contain important information on how to install, use and maintain the appliance.

The manufacturer is not liable if you fail to comply with the instructions and warnings. Retain all documents for subsequent use or for the next owner.

Technical safety

This appliance contains a small quantity of environmentally-friendly but flammable R600a refrigerant. Ensure that the tubing of the refrigerant circuit is not damaged during transportation and installation. Leaking refrigerant may cause eye injuries or ignite.

If damage has occurred

- Keep naked flames and/or ignition sources away from the appliance,
- thoroughly ventilate the room for several minutes,
- switch off the appliance and pull out the mains plug,
- inform customer service.

The more refrigerant an appliance contains, the larger the room must be in which the appliance is situated. Leaking refrigerant can form a flammable gas-air mixture in rooms which are too small.

The room must be at least 1 m³ per 8 g of refrigerant. The amount of refrigerant in your appliance is indicated on the rating plate inside the appliance.

If the power cord of this appliance is damaged, it must be replaced by the manufacturer, customer service or a similarly qualified person.

Improper installations and repairs may put the user at considerable risk.

Repairs may be performed by the manufacturer, customer service or a similarly qualified person only.

Only original parts supplied by the manufacturer may be used.

The manufacturer guarantees that only these parts satisfy the safety requirements.

An extension cable may be purchased from customer service only.

Important information when using the appliance

- Never use electrical appliances inside the appliance (e.g. heater, electric ice maker, etc.). Risk of explosion!
- Never use a steam cleaner to defrost or clean the appliance! The steam may penetrate electrical parts and cause a short-circuit. Risk of electric shock!
- Do not use pointed or sharp-edged implements to remove frost or layers of ice. You could damage the refrigerant tubing. Leaking refrigerant may ignite or cause eye injuries.
- Do not store products which contain flammable propellants (e.g. spray cans) or explosive substances in the appliance. Risk of explosion!
- Do not stand or support yourself on the base, drawers or doors, etc.
- Before defrosting and cleaning the appliance, pull out the mains plug or switch off the fuse. Do not pull out the mains plug by tugging the cable.

- Bottles which contain a high percentage of alcohol must be sealed and stored in an upright position.
- Keep plastic parts and the door seal free of oil and grease. Otherwise, parts and door seal will become porous.
- Never cover or block the ventilation openings for the appliance.
- People (children incl.) who have limited physical, sensory or mental abilities or inadequate knowledge must not use this appliance unless they are supervised or given meticulous instructions.
- Do not store bottled or canned drinks (especially carbonated drinks) in the freezer compartment. Bottles and cans may explode!
- Never put frozen food straight from the freezer compartment into your mouth. Risk of low-temperature burns!
- Avoid prolonged touching of frozen food, ice or the evaporator pipes, etc. Risk of low-temperature burns!

Children in the household

- Keep children away from packaging and its parts. Danger of suffocation from folding cartons and plastic film!
- Do not allow children to play with the appliance!
- If the appliance features a lock: keep the key out of the reach of children!

General regulations

The appliance is suitable

- for refrigerating and freezing food,
- for making ice.

This appliance is intended for use in the home and the home environment.

The appliance is suppressed according to EU Directive 2004/108/EC.

The refrigeration circuit has been checked for leaks.

This product complies with the relevant safety regulations for electrical appliances (EN 60335-2-24).

Information concerning disposal

Disposal of packaging

The packaging protects your appliance from damage during transit.

All utilised materials are environmentally safe and recyclable. Please help us by disposing of the packaging in an environmentally friendly manner.

Please ask your dealer or inquire at your local authority about current means of disposal.

Disposal of your old appliance

Old appliances are not worthless rubbish! Valuable raw materials can be reclaimed by recycling old appliances.



This appliance is identified according to the European guideline 2002/96/EC on waste electrical and electronic equipment – WEEE. The directive specifies the framework for an EU-wide valid return and re-use of old appliances.

Warning

Redundant appliances

1. Pull out the mains plug.
2. Cut off the power cord and discard with the mains plug.
3. Do not take out the trays and receptacles: children are therefore prevented from climbing in!
4. Do not allow children to play with the appliance once it has spent its useful life. Danger of suffocation!

Refrigerators contain refrigerant and gases in the insulation.

Refrigerant and gases must be disposed of professionally. Ensure that tubing of the refrigerant circuit is not damaged prior to proper disposal.

Scope of delivery

After unpacking all parts, check for any damage in transit.

If you have any complaints, please contact the dealer from whom you purchased the appliance or our customer service.

The delivery consists of the following parts:

- Built-in appliance
- Interior fittings (depending on model)
- Bag containing installation materials
- Operating instructions
- Installation manual
- Customer service booklet
- Warranty enclosure
- Information on the energy consumption and noises

Room temperature, ventilation and cavity depth

Ambient temperature

The appliance is designed for a specific climate class. Depending on the climate class, the appliance can be operated at the following temperatures.

The climate class can be found on the rating plate. Fig. 14

Climate class	Permitted ambient temperature
SN	+10 °C to 32 °C
N	+16 °C to 32 °C
ST	+16 °C to 38 °C
T	+16 °C to 43 °C

Note

The appliance is fully functional within the room temperature limits of the indicated climatic class. If an appliance of climatic class SN is operated at colder room temperatures, the appliance will not be damaged up to a temperature of +5 °C.

Ventilation

The air on the rear panel of the appliance heats up. Conduction of the heated air must not be obstructed.

Otherwise, the refrigeration unit must work harder. This increases power consumption. Therefore: Never cover or block the ventilation openings!

Cavity depth

A cavity depth of 560 mm is recommended for the appliance. If the cavity depth is smaller – at least 550 mm – the energy consumption increases slightly.

Installation location

Install the appliance in a dry, well ventilated room. The installation location should neither be exposed to direct sunlight nor near a heat source, e. g. a cooker, radiator, etc. If installation next to a heat source is unavoidable, use a suitable insulating plate or observe the following minimum distances to a heat source:

- 3 cm to electric or gas cookers.
- 30 cm to an oil or coal-fired cooker.

Connecting the appliance

After installing the appliance, wait at least 1 hour until the appliance is switched on. During transportation the oil in the compressor may have flowed into the refrigeration system.

Before switching on the appliance for the first time, clean the interior of the appliance (see chapter “Cleaning the appliance”).

Electrical connection

The socket must be near the appliance and also freely accessible following installation of the appliance.

The appliance complies with the protection class I. Connect the appliance to 220–240 V/50 Hz alternating current via a correctly installed socket with protective conductor. The socket must be fused with a 10 to 16 A fuse.

For appliances operated in non-European countries, check whether the stated voltage and current type match the values of your mains supply. This information can be found on the rating plate. Fig. 14



Warning

Never connect the appliance to electronic energy saver plugs.

Our appliances can be used with mains and sine-controlled inverters.

Mains-controlled inverters are used for photovoltaic systems which are connected directly to the national grid. Sine-controlled inverters must be used for isolated applications (e.g. on ships or in mountain lodges) which are not connected directly to the national grid.

Getting to know your appliance

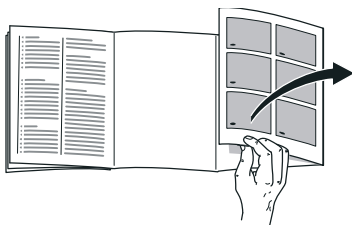

Please fold out the illustrated last page. These operating instructions refer to several models.

The features of the models may vary.

The diagrams may differ.

Fig. 1

* Not all models.

- 1-9 Controls
- 10 * Fan
- 11 Light
- 12 Glass shelf in the refrigerator compartment
- 13 Extendable glass shelf
- 14 Vegetable container
- 15 * Berry tray
- 16 Freezer calendar
- 17 Frozen food container
- 18 Butter and cheese compartment
- 19 Door shelf
- 20 * Vario door shelf
- 21 Shelf for large bottles

- A Refrigerator compartment
- B Freezer compartment

Controls

Fig. 2

- 1 **On/Off button**
Serves to switch the whole appliance on and off.
- 2 **“Super” button (freezer compartment)**
Switches super freezing on and off.
- 3 **Temperature selection buttons freezer compartment**
These buttons set the temperature in the freezer compartment.
- 4 **Temperature display freezer compartment**
The numbers correspond to the set freezer compartment temperatures in °C.
- 5 **Alarm button**
Used to switch off the warning signal, see chapter “Alarm function”.
- 6 **Holiday button**
Is used to switch vacation mode on and off (see chapter entitled Vacation mode).
- 7 **Temperature selection buttons refrigerator compartment**
These buttons set the temperature in the refrigerator compartment.
- 8 **Temperature display refrigerator compartment**
The numbers correspond to the set refrigerator compartment temperatures in °C.
- 9 **“Super” button refrigerator compartment**
Switches super cooling on and off.

Switching the appliance on

Fig. 2

1. Switch on the appliance with the On/Off button 1.
A warning signal sounds, the temperature display 4 flashes and the alarm button 5 is lit.
2. The warning signal is switched off by pressing the alarm button 5.
The appliance begins to cool. Light is switched on when the door is open.

The factory has recommended the following temperatures:

- Refrigerator compartment: +4 °C
- Freezer compartment: -18 °C

Operating tips

- When the appliance has been switched on, it may take several hours until the set temperatures have been reached.
Do not put any food in the appliance beforehand.
- The sides of the housing are sometimes heated slightly. This prevents condensation in the area of the door seal.
- If the freezer compartment door cannot be immediately re-opened after it has been closed, wait until the resulting low pressure has equalised.

Setting the temperature

Fig. 2

Refrigerator compartment

The temperature can be set from +2 °C to +8 °C.

Keep pressing temperature setting button 7 until the required refrigerator compartment temperature is set.

The value last selected is saved. The set temperature is indicated on temperature display 8.

Freezer compartment

The temperature can be set from -16 °C to -24 °C.

Keep pressing temperature setting button 3 until the required freezer compartment temperature is set.

The value last selected is saved. The set temperature is indicated on display 4.

Holiday mode

If leaving the appliance for a long period of time, you can switch the appliance over to the energy-saving holiday mode.

The temperature of the refrigerator compartment is automatically switched to +14 °C.

Do not store any food in the refrigerator compartment during this time.

Switching on and off

Fig. 2

Press the holiday button 6.

If vacation mode is switched on, the button is lit and the refrigerator compartment temperature 8, no longer indicates a temperature.

Alarm functions

Door alarm

The door alarm (continuous sound) switches on if the appliance door is open for longer than one minute. Close the door to switch off the warning signal.

Temperature alarm

The temperature alarm switches on if the freezer compartment is too warm and the frozen food is at risk of thawing.

When the alarm button 5 is pressed, the freezer compartment temperature display 4 indicates for five seconds the warmest temperature reached in the freezer compartment.

Then this value is deleted.

The temperature display for the freezer compartment 4 indicates the set freezer compartment temperature without flashing.

Henceforth the “warmest temperature” will be redefined and saved.

The alarm may switch on without any risk to the frozen food:

- when the appliance is switched on,
- when large quantities of fresh food are placed in the appliance,
- if the freezer compartment door is open too long.

Note

Do not refreeze thawing or thawed food. Only ready meals (boiled or fried) may be refrozen.

No longer store the frozen produce for the max. storage period.

Switching off the alarm

Fig. 2

Press the alarm button 5 to switch off the warning signal.

Usable capacity

Information on the usable capacity can be found inside your appliance on the rating plate. Fig. 14

Fully utilising the freezer volume

The maximum amount of food can be placed in the freezer by removing all fittings. The food can be stacked directly on the shelves and in the bottom of the freezer compartment.

Removing the fittings

Pull out the frozen food container all the way, lift at the front and remove.

Fig. 3

Refrigerator compartment

The refrigerator compartment is the ideal storage location for meat, sausage, fish, dairy products, eggs, ready meals and pastries.

Storing food

- Store fresh, undamaged food. The quality and freshness will then be retained for longer.
- In the case of ready-made products and bottled goods, observe the best-before date or use-by date specified by the manufacturer.
- To retain aroma, colour and freshness, pack or cover food well before placing in the appliance. This will prevent the transfer of flavours and the discolouration of plastic parts in the refrigerator compartment.
- Allow warm food and drinks to cool down before placing in the appliance.

Note

Avoid contact between food and rear panel. Otherwise the air circulation will be impaired.

Food or packaging could freeze to the rear panel.

Note the chill zones in the refrigerator compartment

The air circulation in the refrigerator compartment creates different chill zones:

- Coldest zone is between the arrow stamped on the side and the glass shelf situated below. Fig. 5

Note

Store perishable food (e.g. fish, sausage, meat) in the coldest zone.

- Warmest zone is at the very top of the door.

Note

Store e.g. hard cheese and butter in the warmest zone. Cheese can then continue to release its flavour and the butter will still be easy to spread.

Vegetable container with humidity controller

Fig. 4

The vegetable container is the optimum storage location for fresh fruit and vegetables. A humidity controller and a special seal can be used to adjust the air humidity in the vegetable container. This allows fresh fruit and vegetables to be stored twice as long as with conventional storage.

The air humidity in the vegetable container can be set according to the type and amount of products to be stored:

- Mainly fruit as well as for a large load – lower air humidity
- Mainly vegetables as well as for a mixed load or small load – higher air humidity

Notes

- Fruit sensitive to cold (e.g. pineapple, banana, papaya and citrus fruit) and vegetables sensitive to cold (e.g. aubergines, cucumbers, zucchini, peppers, tomatoes and potatoes) should be stored outside the refrigerator at temperatures of approx. +8 °C to +12 °C for optimum preservation of quality and flavour.
- Condensation may form in the vegetable container depending on the type and quantity of products stored. Remove condensation with a dry cloth and adjust air humidity in the vegetable container with the humidity controller.

Super cooling

Super cooling sets the refrigerator temperature to the coldest temperature setting for approx. 15 hours.

Then the appliance automatically switches to the temperature set prior to super cooling mode.

Switch on super cooling mode, e.g.

- before placing large quantities of food in the refrigerator compartment.
- for the fast cooling of drinks.

Note

When super cooling is switched on, increased operating noises may occur.

Switching on and off

Fig. 2

Press super button 9 refrigerator compartment.

The button is lit when super cooling is switched on.

Freezer compartment

Use the freezer compartment

- To store deep-frozen food.
- To make ice cubes.
- To freeze food.

Note

Ensure that the freezer compartment door has been closed properly. If the door is open, the frozen food will thaw. The freezer compartment will become covered in thick ice. Also: waste of energy due to high power consumption!

Max. freezing capacity

Information about the max. freezing capacity within 24 hours can be found on the rating plate. Fig. 14

Prerequisites for max. freezing capacity

- Switch on super freezing before placing fresh products in the compartment (see chapter entitled “Super freezing”).
- Remove the fittings. The food can be stacked directly on the shelves and in the bottom of the freezer compartment.
- Large quantities of food are frozen most quickly in the top compartment. If the top compartment is not adequate for the freezing capacity indicated on the rating plate, you can place the remaining quantity in the compartment underneath starting at the front right side.
- Freeze fresh food as close as possible to the side panels.

Freezing and storing food

Purchasing frozen food

- Packaging must not be damaged.
- Use by the “use by” date.
- Temperature in the supermarket freezer must be -18 °C or lower.
- If possible, transport deep-frozen food in an insulated bag and place quickly in the freezer compartment.

Note when loading products

- Preferably freeze large quantities of food in the top compartment, where food freezes particularly quickly and therefore also gently.
- Place the food over the whole area of the compartments or the frozen food containers.

Note

Food which is already frozen must not come into contact with the food which is to be frozen. If required, move the frozen food to other frozen food containers.

Storing frozen food

Insert frozen food container all the way to ensure unrestricted air circulation.

Freezing fresh food

Freeze fresh and undamaged food only.

To retain the best possible nutritional value, flavour and colour, vegetables should be blanched before freezing. Aubergines, peppers, zucchini and asparagus do not require blanching.

Literature on freezing and blanching can be found in bookshops.

Note

Keep food which is to be frozen away from food which is already frozen.

- The following foods are suitable for freezing:
Cakes and pastries, fish and seafood, meat, game, poultry, vegetables, fruit, herbs, eggs without shells, dairy products such as cheese, butter and quark, ready meals and leftovers such as soups, stews, cooked meat and fish, potato dishes, soufflés and desserts.
- The following foods are not suitable for freezing:
Types of vegetables, which are usually consumed raw, such as lettuce or radishes, eggs in shells, grapes, whole apples, pears and peaches, hard-boiled eggs, yoghurt, soured milk, sour cream, crème fraîche and mayonnaise.

Packing frozen food

To prevent food from losing its flavour or drying out, place in airtight containers.

1. Place food in packaging.
2. Remove air.
3. Seal the wrapping.
4. Label packaging with contents and date of freezing.

Suitable packaging:

Plastic film, tubular film made of polyethylene, aluminium foil, freezer containers.

These products are available from specialist outlets.

Unsuitable packaging:

Wrapping paper, greaseproof paper, cellophane, bin liners and used shopping bags.

Items suitable for sealing packaged food:

Rubber bands, plastic clips, string, cold-resistant adhesive tape, etc.

Bags and tubular film made of polyethylene can be sealed with a film heat sealer.

Shelf life of frozen food

Storage duration depends on the type of food.

At a temperature of -18 °C:

- Fish, sausage, ready meals and cakes and pastries:
up to 6 months
- Cheese, poultry and meat:
up to 8 months
- Vegetables and fruit:
up to 12 months

Super freezing

Food should be frozen solid as quickly as possible in order to retain vitamins, nutritional value, appearance and flavour.

Several hours before placing fresh food in the freezer compartment, switch on super freezing to prevent an unwanted temperature rise.

As a rule, 4-6 hours is adequate.

This appliance runs constantly and the freezer compartment drops to a very low temperature.

If the max. freezing capacity is to be used, super freezing must be switched on for 24 hours before the fresh produce is placed in the freezer compartment.

You can place smaller quantities of food (up to 2 kg) in the top compartment without super freezing.

Note

When super freezing is switched on, increased operating noises may occur.

Switching on and off

Fig. 2

Press "super" button 2.

If the super freezing has been switched on the button is lit.

Super freezing automatically switches off after approx. 2½ days.

Thawing frozen food

Depending on the type and application, select one of the following options:

- at room temperature
- in the refrigerator
- in an electric oven, with/without fan assisted hot-air
- in the microwave

Caution

Do not refreeze thawing or thawed food. Only ready meals (boiled or fried) may be refrozen.

No longer store the frozen produce for the max. storage period.

Interior fittings

(not all models)

Glass shelves

Fig. **6**

If required, you can vary the shelves inside the appliance: To do this, pull out shelf, lift at the front and take out.

Extendable glass shelf

Fig. **7**

The extendable glass shelf can be pulled out for a better overview of the food.

Vario shelf

Fig. **8**

To facilitate the storage of tall items (e.g. cans or bottles), the front part of the Vario shelf can be taken out and pushed under the rear part.

Vario door shelf

Fig. **9**

The position of the Vario door shelf can be moved to the side so that tall bottles can be stored on the lower shelf.

Bottle holder

Fig. **10**

The bottle holder prevents bottles from falling over when the door is opened and closed.

Freezer calendar

Fig. **11**/16

To prevent the quality of the frozen food from deteriorating, do not exceed the storage duration. The storage period depends on the type of produce.

The figures next to the symbols indicate the permitted storage period of the produce in months. In the case of commercially available frozen food observe the date of manufacture or use-by date.

Ice cube tray

Fill the ice cube tray $\frac{3}{4}$ full of drinking water and place in the freezer compartment.

If the ice tray is stuck to the freezer compartment, loosen with a blunt implement only (spoon-handle).

To loosen the ice cubes, twist the ice tray slightly or hold briefly under flowing water.

Ice pack

(if enclosed, quantity varies)

If a power failure or malfunction occurs, the ice packs can be used to slow down the thawing process. The longest storage time is obtained by placing the ice pack on the food in the top compartment.

The ice packs can also be used to cool food temporarily, e.g. in a cold bag.

Sticker “OK”

(not all models)

The “OK” temperature monitor can be used to determine temperatures below +4 °C. Gradually reduce the temperature if the sticker does not indicate “OK”.

Note

When the appliance is switched on, it may take 12 hours until the temperature is reached.



Correct setting

Switching off and disconnecting the appliance

Switching off the appliance

Fig. 2

Press the On/Off button 1. Temperature display goes out, refrigerating unit switches off.

Disconnecting the appliance

If you do not use the appliance for a prolonged period:

1. Switch off the appliance.
2. Pull out mains plug or switch off fuse.
3. Clean the appliance.
4. Leave the appliance door open.

Defrosting

Refrigerator compartment defrosts fully automatically

While the refrigerating unit is running, beads of condensation or hoarfrost form at the back of the refrigerator compartment. This is quite normal. It is not necessary to wipe off the condensation or frost. The rear panel defrosts automatically. The condensation runs into the condensation channel, Fig. 11, and is conveyed to the refrigerating unit where it evaporates.

Note

Keep the condensation channel and drainage hole clean, so that the condensation can run out.

Defrosting the freezer compartment

The freezer compartment does not defrost automatically, otherwise the frozen food would start thawing. A layer of frost in the freezer compartment impairs refrigeration of the frozen food and increases power consumption. Remove the layer of hoarfrost regularly.

Caution

Do not scrape off hoarfrost or ice with a knife or pointed object. You could damage the refrigerant tubes. Leaking refrigerant may ignite or cause eye injuries.

Proceed as follows:

Note

Approx. 4 hours before defrosting the appliance, switch on super freezing so that the food drops to a very low temperature and can therefore be stored at room temperature for a longer period.

1. Remove the frozen food and place temporarily in a cool location.
2. Switch the appliance off.
3. Pull out the mains plug or remove the fuse.
4. To accelerate the defrosting process, place a pan of hot water on a trivet in the freezer compartment. Fig. 12
5. Wipe up condensation with a cloth or sponge.
6. Wipe dry the freezer compartment.
7. Switch the appliance on again.
8. Put the frozen food back in the freezer compartment.

Cleaning the appliance

Caution

- Do not use abrasive, chloride or acidic cleaning agents or solvents.
- Do not use scouring or abrasive sponges. The metallic surfaces could corrode.
- Never clean the shelves or containers in the dishwasher. The parts may become deformed!

Proceed as follows:

1. Before cleaning: Switch off the appliance.
2. Pull out the mains plug or switch off the fuse!
3. Take out the food and store in a cool location. Place ice pack (if available) on the food.
4. Wait until the layer of frost has thawed.
5. Clean the appliance with a soft cloth, lukewarm water and a little pH neutral washing-up liquid. The rinsing water must not run into the light or through the drainage hole into the evaporation area.
6. Wipe the door seal with clear water only and then wipe dry thoroughly.
7. After cleaning reconnect and switch the appliance back on.
8. Put the food back into the appliance.

Interior fittings

All variable parts of the appliance can be taken out for cleaning.

Take out glass shelves

Fig. 6

To do this, pull out shelf, lift at the front and take out.

Taking out extendable glass shelf

Fig. 7

Press levers on the underside on both sides, pull forwards glass shelf, lower and swivel out to the side.

Condensation channel

Fig. 11

Regularly clean the condensation channel and drainage hole with a cotton bud or similar implement to ensure that the condensation can drain.

Take out shelves in the door

Fig. 13

Lift shelves upwards and take out.

Taking out glass shelf above vegetable container

Fig. 15

The glass shelf can be taken out and disassembled for cleaning.

Note

Before taking out the glass shelf, pull out vegetable container.

Removing the container

Fig. 3

Pull out the container all the way, lift at the front and remove.

Odours

If you experience unpleasant odours:

1. Switch off the appliance with the On/Off button. Fig. 2/1
2. Take all food out of the appliance.
3. Clean interior (see chapter "Cleaning the appliance").
4. Clean all packages.
5. Seal strong smelling food in order to avoid odours from forming.
6. Switch the appliance on again.
7. Store food in the appliance.
8. Check whether the formation of odours is still occurring after 24 hours.

Light (LED)

Your appliance features a maintenance-free LED light.

These lights may be repaired by customer service or authorised technicians only.

Tips for saving energy

- Install the appliance in a dry, well ventilated room! The appliance should not be installed in direct sunlight or near a heat source (e.g. radiator, cooker).

If required, use an insulating plate.

- Select 560 mm cavity depth.
A smaller cavity depth will result in a higher energy consumption.
- Allow warm food and drinks to cool down before placing in the appliance.
- Thaw frozen food in the refrigerator compartment and use the low temperature of the frozen food to cool refrigerated food.
- Open the appliance as briefly as possible.
- Regularly defrost the freezer compartment to remove the layer of frost.
A layer of hoarfrost will impair refrigeration of the frozen food and increase power consumption.
- Ensure that the freezer compartment door is always closed properly.
- Occasionally clean the rear of the appliance to prevent an increased power consumption.
- The arrangement of the fittings does not affect the energy rating of the appliance.

Operating noises

Quite normal noises

Droning

Motors are running (e.g. refrigerating units, fan).

Bubbling, humming or gurgling noises

Refrigerant is flowing through the tubing.

Clicking

Motor, switches or solenoid valves are switching on/off.

Preventing noises

The appliance is not level

Please align the appliance with a spirit level. If required, place something underneath.

Containers or storage areas wobble or stick

Please check the removable parts and re-insert them correctly if required.

Bottles or receptacles are touching each other

Move the bottles or receptacles slightly away from each other.

Eliminating minor faults yourself

Before you call customer service:

Please check whether you can eliminate the fault yourself based on the following information.

Customer service will charge you for advice – even if the appliance is still under guarantee!

Fault	Possible cause	Remedial action
Temperature differs greatly from the set value.		<p>In some cases it is adequate to switch off the appliance for 5 minutes.</p> <p>If the temperature is too high wait a few hours and check whether the temperature has approached the set value.</p> <p>If the temperature is too low check the temperature again the next day.</p>
Displays do not illuminate.	Power failure; the fuse has been switched off; the mains plug has not been inserted properly.	Connect mains plug. Check whether the power is on, check the fuses.
Temperature display indicates "E..".	Electronics have detected a fault.	Call customer service.
Warning signal sounds, "alarm" button lights up. Fig. 2/5	Appliance is open.	To switch off the warning signal, press the "alarm" button 5.
	Ventilation openings have been covered.	Close the appliance. Ensure that there is adequate ventilation.
The freezer compartment is too warm! Frozen food is at risk!	Too much food was placed in the freezer compartment at once.	Do not exceed max. freezing capacity.
		When the fault has been eliminated, the "alarm" button 5 goes out shortly afterwards.

Fault	Possible cause	Remedial action
<p>Freezer compartment temperature display flashes. Fig. 2/4</p> <p>Warning signal sounds.</p> <p>The alarm button is lit. Fig. 2/5</p> <p>The freezer compartment is too warm!</p> <p>Frozen food is at risk!</p>	<p>Appliance is open.</p> <p>Ventilation openings have been covered.</p> <p>Too much food was placed in the freezer compartment at once.</p>	<p>To switch off the warning signal, press the “alarm” button, Fig. 2/5.</p> <p>Close the appliance.</p> <p>Ensure that there is adequate ventilation.</p> <p>Do not exceed max. freezing capacity.</p> <p>When the fault has been eliminated, the alarm display goes out shortly afterwards.</p>
<p>Freezer compartment temperature display flashes. Fig. 2/4</p>	<p>A fault caused the freezer compartment to become too warm in the past.</p>	<p>When the alarm button 5 is pressed, the temperature display stops flashing. Fig. 2/4</p> <p>The temperature display indicates for 5 seconds the warmest temperature which was reached in the freezer compartment.</p>
<p>Appliance is not cooling, temperature display and light are lit.</p>	<p>Showroom mode is switched on.</p>	<p>Hold down alarm button, Fig 2/5, for 10 seconds until an acknowledgement signal sounds.</p> <p>After a short time check whether your appliance is cooling.</p>

Appliance self-test

Your appliance features an automatic self-test program which shows you sources of faults which may be repaired by customer service only.

Starting the appliance self-test

1. Switch off the appliance and wait 5 minutes.
2. Switch the appliance on.
3. Press alarm button, Fig. 2/5, to switch off the warning signal.

If there is no warning signal, this step is not applicable.

4. Within the first 10 seconds after switching on the appliance, hold down the super button, Fig. 2/2, for 3 to 5 seconds until an acoustic signal sounds.

The self-test programme starts. While the self-test is running, a long acoustic signal sounds.

When the self-test ends and an acoustic signal sounds twice, your appliance is in working order.

If the super button flashes for 10 seconds and 5 acoustic signals sound, there is a fault. Inform customer service.

Ending the appliance self-test

When the programme has ended, the appliance switches over to normal operation.

Customer service

Your local customer service can be found in the telephone directory or in the customer-service index.

Please provide customer service with the appliance product number (E-Nr.) and production number (FD).

These specifications can be found on the rating plate. Fig. 14

To prevent unnecessary call-outs, please assist customer service by quoting the product and production numbers. This will save you additional costs.

Repair order and advice on faults

Contact information for all countries can be found on the enclosed customer service list.

GB	0844 892 8999	Calls from a BT landline will be charged at up to 3 pence per minute. A call set-up fee of up to 6 pence may apply.
IE	01450 2655	
US	866 447 4363	toll-free

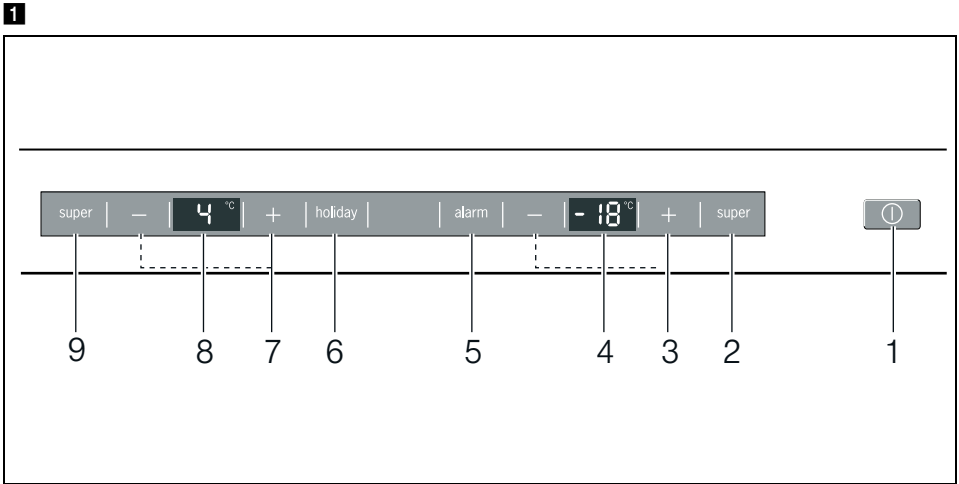
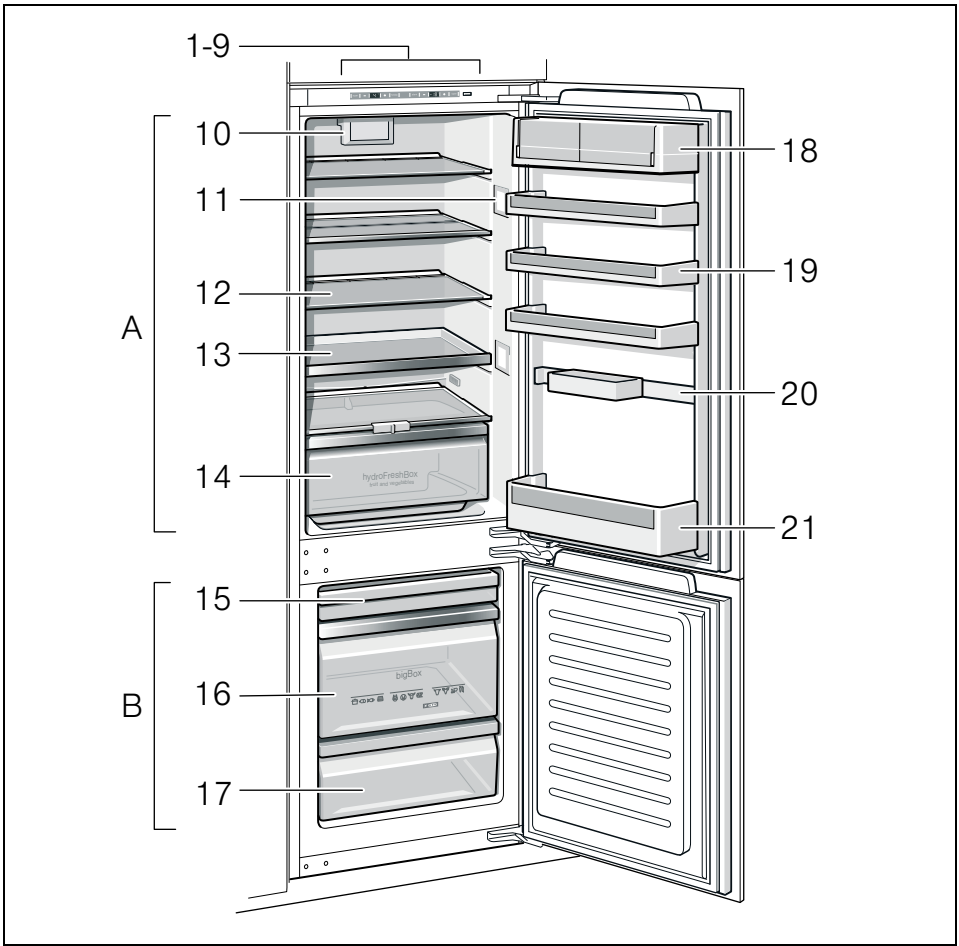

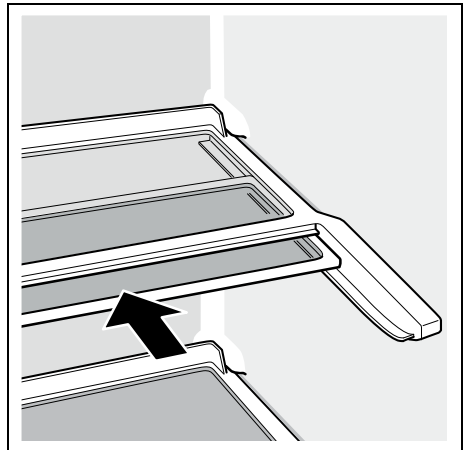
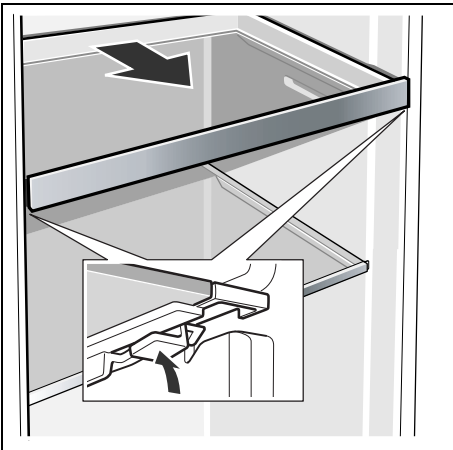
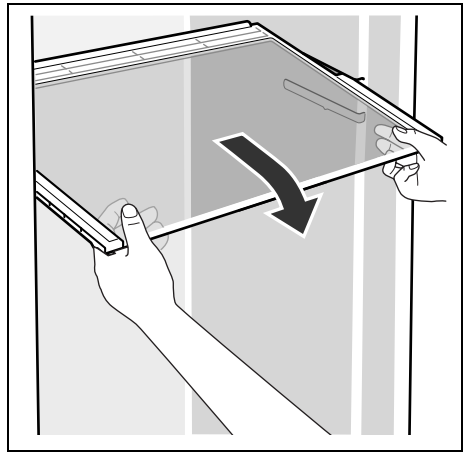
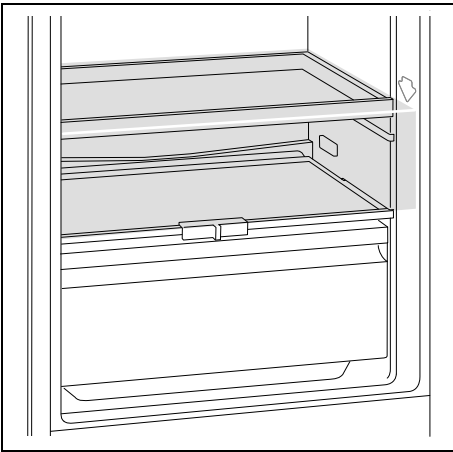
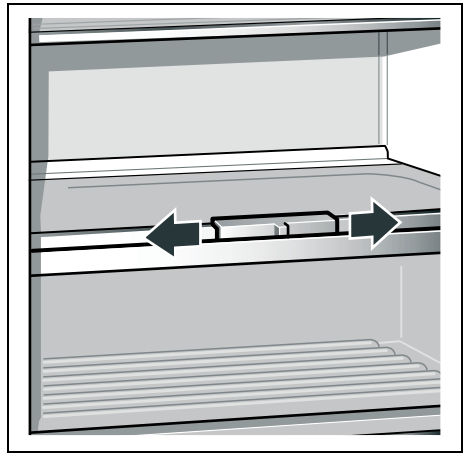
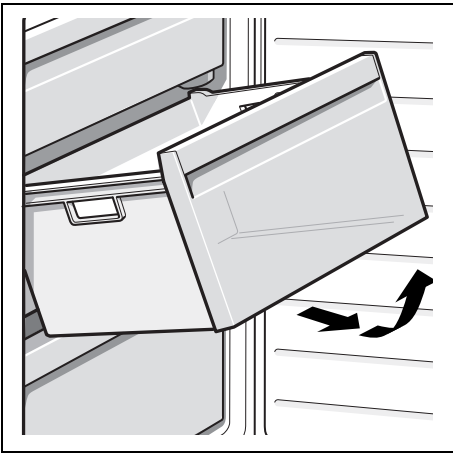

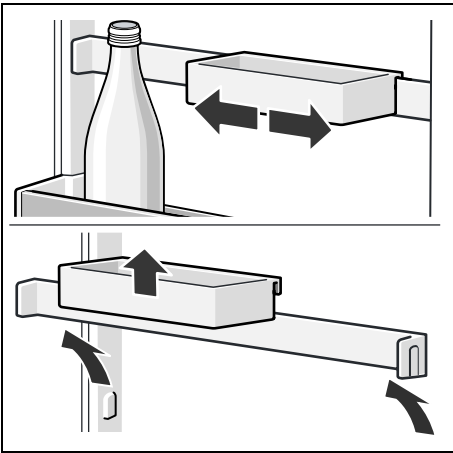

9

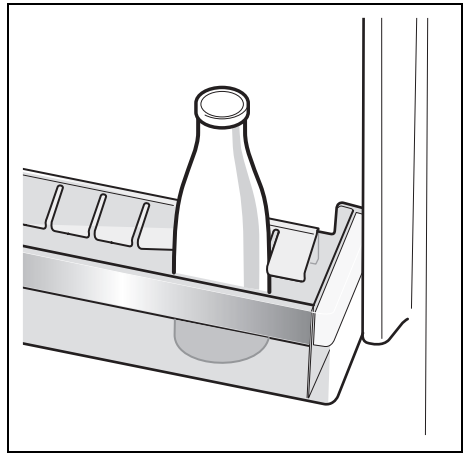

10



11



12

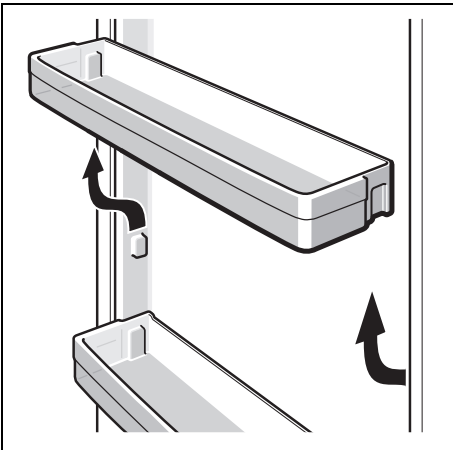

13



14

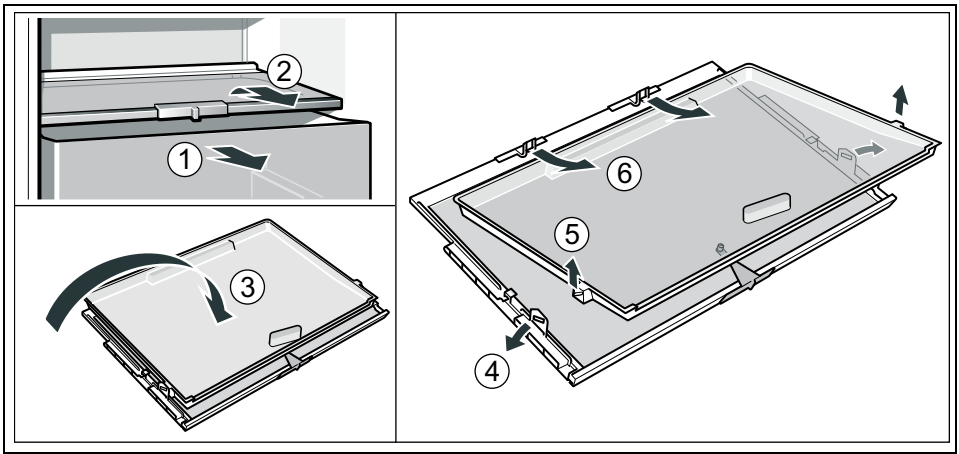

Siemens-Elektrogeräte GmbH
Carl-Wery-Str. 34, 81739 München
Germany



9000767482 en (9212)